

# BMI<sup>®</sup>

Measuring Instruments  
...measuring the progress



# CONTENTS

BMI

## Pocket Tapes & Rulers

Flexible Steel Rules	Page:	3
Rigid Steel Rules	Page:	3
High Precision Pocket Tapes	Page:	4
Robust Pocket Tapes	Page:	5
Specialty Pocket Tapes	Page:	5
Carpenters Square	Page:	6
Telescopic measuring rod	Page:	6
Measuring Wheels	Page:	7

## Measuring Tapes

Enamelled Steel Tapes	Page:	6
Fibreglass Reinforced Tapes	Page:	7
Closed Reel tape	Page:	10
Measuring Wheel	Page:	10

## Spirit Levels

'Eurostar' Spirit Levels	Page:	11
'Superstar PLUS' Spirit Level	Page:	12
'Robust' Spirit Levels	Page:	13
'HighPrecision' Spirit Levels	Page:	14
Wooden Bamboo Spirit Level	Page:	14
'INCLITRONIC' electronic Level	Page:	15
LEVELBOY Electronic level	Page:	15
AngleStar Spirit Level	Page:	18
Folding Angle Level	Page:	18
'Ultrasonic' Spirit Level	Page:	19
'Torpedo' Spirit Levels	Page:	19
Line Level Spirit Level	Page:	19
Spirit Levels Packs & Display	Page:	16-17

## Laser Levels

'Nautilus' Construction Laser	Page:	20
'multiLASER' Construction Laser	Page:	21
'autoCROSS' Construction Laser	Page:	22
LASERBOY II	Page:	23



## Pocket Tapes & Rulers

### Accuracy, Quality & Durability

Made in Germany, the range of BMI measuring tapes, pocket tapes and rulers are designed for accuracy and long service life, to provide you with the perfect solution for every measuring task.

Each steel tape is graduated in black for clarity, and the strong, construction and patented features means you can rely on BMI measuring tools for accurate measurement every time.

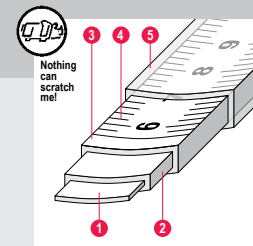

1. Concave, tempered spring blade steel of high stability.
2. Anticorrosive phosphate coating.
3. Heat treated synthetic resin
4. Printed graduation with red meter figures
5. Heat treated clear varnish to protect against wear

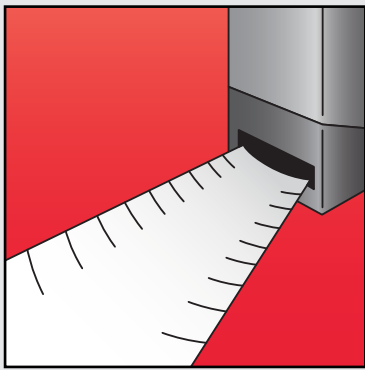

### 962 FLEXIBLE

#### 13MM FLEXIBLE STEEL RULE



- Stainless, hard rolled spring band steel
- Accurate according to EC Class II
- Cross Section 13mm x 0.5mm
- Black graduation (mm)
- Graduation largely anti-abrasive and withstands chemicals, grease and oil
- Rounded edges

Hang tagged for shop display



cat.-no.	length (cm)	graduation (top edge)	graduation (bottom edge)
962-0150-30	15	1/2mm	1mm
962-0150-50	15	1/16, 1/32, 1/64"	1/2, 1mm
962-0300-30	30	1/2mm	1mm
962-0300-50	30	1/16, 1/32, 1/64"	1/2, 1mm

### 963 FLEXIBLE

#### 18MM FLEXIBLE STEEL RULE



- Stainless, hard rolled spring band steel
- Accurate according to EC Class II
- Cross Section 18mm x 0.5mm
- Black graduation (mm)
- Graduation largely anti-abrasive and withstands chemicals, grease and oil
- Rounded edges

Hang tagged for shop display



cat.-no.	length (cm)	graduation (top edge)	graduation (bottom edge)
963-0150-60	15	1/2, 1 mm	1/16, 1/32, 1/64"
963-1000-30	100	1/2mm	1mm
963-1000-50	100	1/16, 1/32, 1/64"	1/2, 1mm
963-2000-30	200	1/2mm	1mm

### 966 RIGID

#### RIGID STEEL RULE



- Stainless, hard rolled spring band steel
- Accurate according to EC Class II
- Cross Section 30mm x 1mm
- Black graduation (mm)
- Graduation largely anti-abrasive and withstands chemicals, grease and oil
- Rounded edges

Hang tagged for shop display



cat.-no.	length (cm)	graduation (top edge)	graduation (bottom edge)
966-0300-60	30	1/2, 1mm	1/16, 1/32, 1/64"
966-0300-40	30	1mm	1mm
966-0600-40	60	1mm	1mm
966-1000-30	100	1/2mm	1mm

411 VARIO HIGH PRECISION

HIGH PRECISION POCKET TAPE

- Accurate according to EC Class I - High Precision
- White enamelled steel tape
- High impact ABS case
- Black graduation (mm)

Accurate to EC Class I

3m : ±0.5mm  
5m : ±0.7mm  
8m : ±1.0mm



cat.-no.	tape length (m)	tape width (mm)	body size (mm)
411-05-HP	5	16	75 x 70 x 26
411-08-HP	8	19	78 x 77 x 32

411 VARIO HIGH PRECISION

HIGH PRECISION POCKET TAPE

- Accurate according to EC Class I - High Precision
- White enamelled steel tape
- High impact ABS case
- Black graduation (mm)
- Full stainless steel internals (tape, springs, screws)

Accurate to EC Class I

3m : ±0.5mm  
5m : ±0.7mm  
8m : ±1.0mm



cat.-no.	tape length (m)	tape width (mm)	body size (mm)
411-03-HP	3	13	60 x 58 x 19
411-05-HP	5	16	75 x 70 x 26
411-08-HP	8	19	78 x 77 x 32

405 VISO

3 FUNCTION TAPE

- 3 special measuring functions
  - Longitudinal measuring
  - Internal measuring using 'top sight' window
  - Circles
- Tape lock
- Polyamide case
- Black graduation (mm)

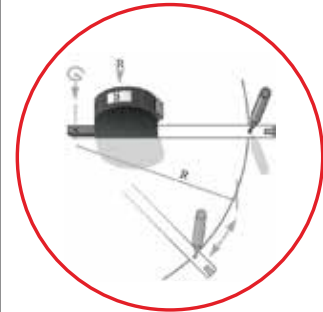

Measure circles with ease



cat.-no.	tape length (m)	tape width (mm)	body size (mm)
405-03	3	16	65 x 65 x 25

7 ADVANTAGES EXCLUSIVE TO BMI-VARIO POCKET TAPES

<p><b>LIGHTNESS</b> 25 % less volume, 5 % less weight – the ideal pocket tape for the professional</p>	<p><b>RECOIL-FREE</b> Special curved T-formed damper made out of rubber absorbs the recoil energy. Even the intensive blade return of the 8 m tape will be comfortable for your wrist.</p>	<p><b>EFFORTLESS LOCKING</b> Particularly handy and smooth press button for a safe locking of the tape. A light press with the finger is sufficient. The "fixed press" is no longer necessary.</p>	<p><b>TREMENDOUSLY SMOOTH</b> The arbor and the outlet are manufactured out of liquid-bearing technology material TRIBOCOMP® with Teflon which provides a tremendously smooth slide and a very easy roll in of the tape.</p>
<p><b>HOOK-AIRBAG</b> The high outlet of the tape protects the stainless steel hook from damage and deformation upon return.</p>	<p><b>BELT-FRIENDLY</b> Belt clip made out of smooth stainless steel wire without any sharp edges. You can easily and quickly attach your VARIO to your belt.</p>	<p><b>SCRATCH ME IF YOU CAN!</b> The clear varnish protects the tape against wear. The white enamelled tapes are anti-glare, this will protect your eyes and wallet at the same time.</p>	

## 472 twoComp

### ROBUST POCKET TAPE

- Robust pocket tape
- High impact ABS case
- Automatic blade return
- Tape lock
- Belt clip
- Black graduation (mm)



cat.-no.	tape length (m)	tape width (mm)	body size (mm)
472-03	3	16	60 x 60 x 32
472-05	5	19	70 x 70 x 36
472-08	8	25	80 x 80 x 45
472-10	10	30	88 x 88 x 45

## 472 twoComp MAGNETIC

### MAGNETIC POCKET TAPE

- Magnetic
- Robust pocket tape
- High impact ABS case
- Automatic blade return
- Tape lock
- Belt clip
- Black graduation (mm)



cat.-no.	tape length (m)	tape width (mm)	body size (mm)
472-05-M	5	19	70 x 70 x 36
472-08-M	8	25	80 x 80 x 45
472-10-M	10	30	88 x 88 x 45

## PICO

### PICO RULE AND LEVEL

- Combines ruler and level in one tool
- Accurate to ECC Class II (1mm/1m)
- Stainless steel tape
- Waterproof
- Curved glass enables easy reading of level
- Black graduation (mm)



2 in 1 Marking & levelling



Vertical Level



Horizontal Level



cat.-no.	tape length (m)	tape width (mm)	body size (mm)
426-01	1	19	62 x 25 x 52

## 429 BMImeter

### BMImeter



- White enamelled, stainless steel tape
- Waterproof
- Unbreakable
- Accurate to EC Class II ( $\pm 0.9\text{mm}/2\text{m}$ )
- Compact design
- Black graduation (mm)



Tape lies flat



Waterproof, stainless steel



Unbreakable



cat.-no.	tape length (m)	tape width (mm)
429-02	2	16

950 Carpenter's Square

**CARPENTER'S SQUARE - COATED**

- Carpenter's angle for drawing the right angles
- Precise extension of cutting lines.
- Yellow, powder-coated design

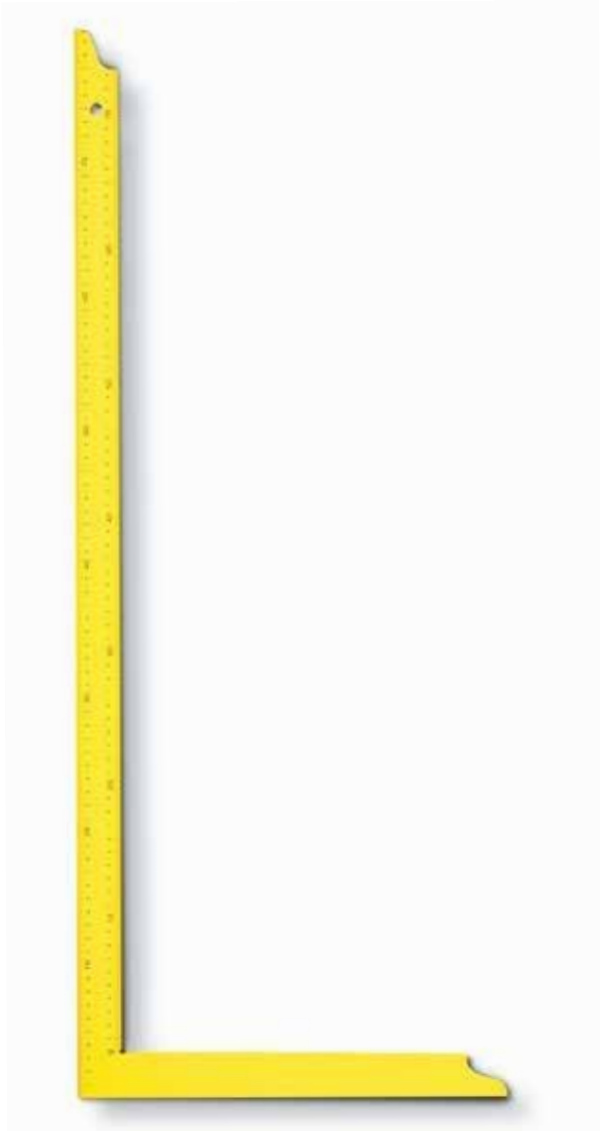

cat.-no.	length (cm)
950-070-001	70

710 Telescopic measuring rod

**TELESCOPIC MEASURING ROD**

- Anodized aluminium profile with a telescopic section clamp
- Length max. 5 or 8 m
- Telescopic parts 5 (for 5 m) 6 (for 8 m)
- Reading display
- With a telescope section clamp



cat.-no.	vials	length(cm) [min-max]	cross section (mm)
710-504-5	1	103-500	38 x 36
710-504-8	1	153-800	38 x 36

## 700 Rollfix Easy

### MEASURING WHEEL

- This distance measuring device made of high-quality plastic
- Includes both advantages of low weight with a large measuring wheel
- Forward and backward measuring
- Lever-operated counter reset
- The swing-out stand and the built-in parking brake help handling
- The guide rod can be folded for transportation.
- Carrying case is included



cat.-no.	Tolerance	Total height (mm)	Wheel Diameter (mm)
700-1994	1%	990	318.3 (1 m girth)

## 700 Rollfix Easy 2

### MEASURING WHEEL

- This distance measuring device made of high-quality plastic
- Includes both advantages of low weight with a large measuring wheel
- Forward and backward measuring
- Lever-operated counter reset
- The swing-out stand and the built-in parking brake help handling
- The guide rod can be folded for transportation.
- Carrying case is included



cat.-no.	Tolerance	Total height (mm)	Wheel Diameter (mm)
700-1996	below 1%	1050	318.3 (1 m girth)



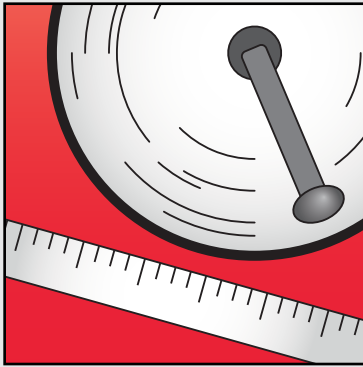

## Measuring Tapes

### The Right Choice

When you use BMI Measuring Tapes, you're taking advantage of patented features that make your job easier, saving time, money, and effort.

Featuring high quality construction, ergonomic design and compliant to EC Accuracy Class II, the range of BMI measuring tapes provide you with the perfect measuring solution for every task.



The FLEXTOP tip is made of transparent, highly-flexible plastic; reliably preventing breakage at the tape commencements.

For all steel measuring tapes 13 mm, the pull ring is made of break-proof plastic, with 2 notches for grip.

### 305 ISOLAN

#### ERGOLINE MEASURING TAPE

- Yellow, enamelled steel tape
- Accurate according to EC Class II ( $\pm 2.3\text{mm}/10\text{m}$ )
- ERGOLINE frame series
- 13mm hookring with FLEXTOP tip
- Measurement commences at front fitting edge
- Black graduation (mm)
- Ergonomically shaped frame
- Easy grip, rubber coated handle
- Park position for crank arm
- Ball bearings for ease of winding
- 13mm tape width

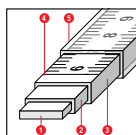
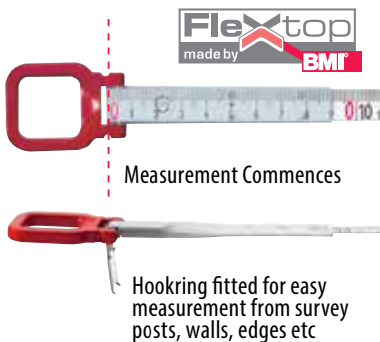

1. Tempered spring blade, made of Carbon Steel C75.
2. Anticorrosive phosphate layer.
3. Heat treated, yellow synthetic resin
4. Printed graduation with red meter digits
5. Polyamide coating to protect against wear

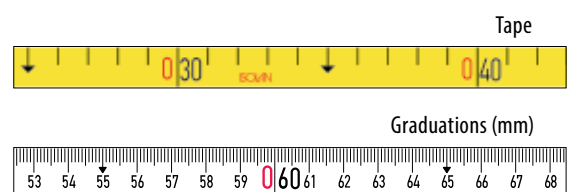

cat.-no.	frame size	tape length (m)	tape width (mm)
305-030	3	30	13
305-050	4	50	13
305-100	4	100	13



## 501 WHITE ENAMELLED

### WHITE ENAMELLED MEASURING TAPE

- White, enamelled steel tape
- Accurate according to EC Class II ( $\pm 2.3\text{mm}/10\text{m}$ )
- 13mm hookring with FLEXTOP tip
- Measurement commences at front fitting edge
- Black graduation (mm)
- High-impact plastic frame
- Slide rings for ease of winding
- 13mm tape width

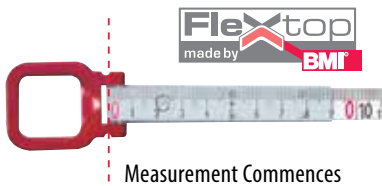

Measurement Commences



Hookring fitted for easy measurement from survey posts, walls, edges etc

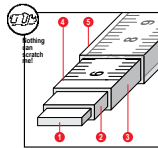

1. Tempered spring blade steel of high stability.
2. Anticorrosive phosphate layer.
3. Heat treated synthetic resin
4. Printed graduation with red meter digits
5. Heat treated clear varnish to protect against wear

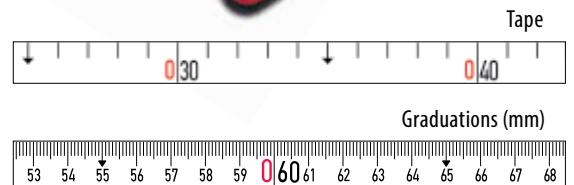

Tape

Graduations (mm)

cat.-no.	frame size	tape length (m)	tape width (mm)
501-030	33	30	13
501-050	33	50	13
501-100	34	100	13

## 520 FIBREGLASS

### FIBREGLASS REINFORCED MEASURING TAPE

- Fibreglass reinforced tape
- Accurate according to EC Class II ( $\pm 2.3\text{mm}/10\text{m}$ )
- 13mm hookring with FLEXTOP tip
- Measurement commences at front fitting edge
- Black graduation (mm)
- High-impact plastic frame
- Slide rings for ease of winding
- 13mm tape width

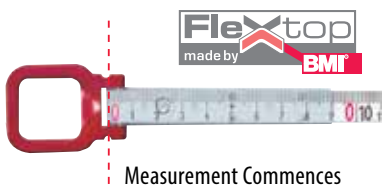

Measurement Commences



Hookring fitted for easy measurement from survey posts, walls, edges etc

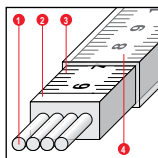

1. Glass fibres.
2. Extruded plastic coating.
3. Printed graduation with red metre figures
4. Varnished against wear

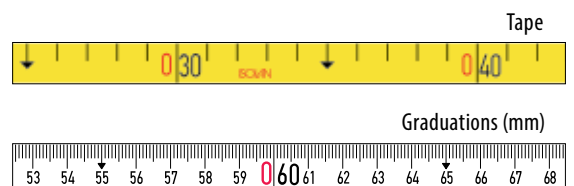

Tape

Graduations (mm)

cat.-no.	frame size	tape length (m)	tape width (mm)
520-030	33	30	13
520-050	34	50	13

700 Radius

WHITE ENAMELLED - CLOSED REEL TAPE

- Ergonomically shaped frame
- Can be modified from right-hand to left-hand operation in no time
- Wear-resistant slide bearing
- Park position for the tape commencement ring
- Park position for crank arm
- The FLEXTOP tip prevents breakage at the tape commencement
- Easy-grip soft-touch surface



cat.-no.	frame size (mm)	tape length (m)	tape width (mm)
501-21-020	140 x 115 x 34	20	13
501-22-030	174 x 145 x 34	30	13
501-23-050	213 x 180 x 34	50	13

700 Rollfix Easy 2

MEASURING WHEEL

- This distance measuring device made of high-quality plastic
- Includes both advantages of low weight with a large measuring wheel
- Forward and backward measuring
- Lever-operated counter reset
- The swing-out stand and the built-in parking brake help handling
- The guide rod can be folded for transportation.
- Carrying case is included



cat.-no.	frame size (mm)	tape length (m)	tape width (mm)
573-030	335 x 205 x 40	30	13
573-050	355 x 235 x 40	50	13
573-100	450 x 320 x 50	100	13

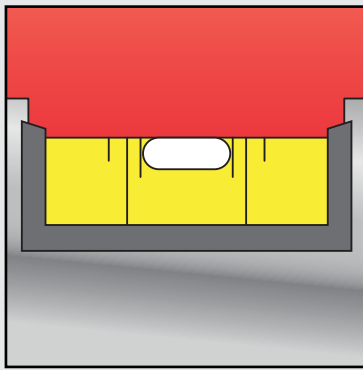

## Spirit Levels

### High Precision and Guaranteed Durability

BMI Levels feature domed vials to enable easy reading from any angle, plus ultrasonic welded vials with an accuracy of up to 0.3mm/m, to ensure perfect measurements throughout the tools working life.

The 'ROBUST' and 'HIGHPRECISION' levels are manufactured with a unique 4 chambered profile body, the strongest profile on the market, plus thick, shock absorbing rubber end caps to protect against impacts for life.

#### 690 EUROSTAR

##### 'EUROSTAR' SPIRIT LEVEL

- Accurate to 0.5mm/m (including inverted measurements)
- 2% fall line marked on vials
- Additional BMI patented "Precision Reading" marked on vials after fitting to ensure the highest accuracy
- 2x ultrasonic welded vials
- (3 vials in Art. 690-120-ES & 690-200-ES only)
- 1.5mm thick, box-section aluminium construction
- Shock-absorbing rubber end caps

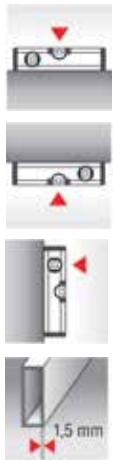

Go to page 12 to see  
'EUROSTAR' Spirit  
Level Packs

cat.-no.	vials	length (cm)	cross section (mm)
690-040-P	2	40	50 x 22
690-060-P	2	60	50 x 22
690-080-P	2	80	50 x 22
690-090-P	2	90	50 x 22
690-120-PS	3	120	50 x 22
690-200-PS	3	200	50 x 22

#### 690 EUROSTAR MAGNETIC

##### 'EUROSTAR' SPIRIT LEVEL - MAGNETIC

- Magnetic body for ease of use
- Accurate to 0.5mm/m (including inverted measurements)
- 2% fall line marked on vials
- Additional BMI patented "Precision Reading" marked on vials after fitting to ensure the highest accuracy
- 2x ultrasonic welded vials
- 1.5mm thick, box-section aluminium construction
- Shock-absorbing rubber end caps



cat.-no.	vials	length (cm)	cross section (mm)
690-120-PMS	3	120	50 x 22

## 697 SUPERSTAR PLUS

### 'SUPERSTAR PLUS' SPIRIT LEVEL

- Original BMI domed round horizontal vial for unsurpassed readability
- Accurate to 0.5mm/m (including inverted measurements)
- 2x ultrasonic welded vials (3 vials in Art. 699-120-AS & 699-200-AS)
- 1.65mm thick, box-section aluminium construction (2.3mm in Art. 699-200-AS)
- Milled measuring surface
- Shock-absorbing rubber end caps



Go to page 12 to see 'SUPERSTAR PLUS' Spirit Level Packs



## 697 SUPERSTAR PLUS MAGNETIC

### 'SUPERSTAR PLUS' SPIRIT LEVEL - MAGNETIC

- Magnetic body for ease of use
- Original BMI domed round horizontal vial for unsurpassed readability
- Accurate to 0.5mm/m (including inverted measurements)
- 2x ultrasonic welded vials
- 1.65mm thick, box-section aluminium construction
- Milled measuring surface
- Shock-absorbing rubber end caps



cat.-no.	vials	length (cm)	cross section (mm)
697-030-A	2	30	50 x 26
697-040-A	2	40	50 x 26
697-060-A	2	60	50 x 26
697-080-A	2	80	50 x 26
697-100-A	2	100	50 x 26
697-120-AS	3	120	50 x 26
697-150-AS	3	150	50 x 26
697-200-AS	3	200	50 x 26

cat.-no.	vials	length (cm)	cross section (mm)
697-120-MS	3	120	50 x 26
697-200-MS	3	200	50 x 26



## 698 ROBUST

### 'ROBUST' SPIRIT LEVEL

- Original BMI domed round vial with magnifying effect - unsurpassed readability
- Accurate to 0.5mm/m (including inverted measurements)
- 3x ultrasonic welded vials
- Torsion resistant 4-chamber profile
- 2mm thick aluminium construction
- 2 milled measuring surfaces
- Extra thick shock-absorbing rubber end caps
- Powder coated red

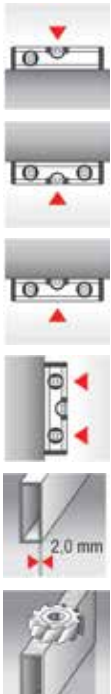

Go to page 12 to see 'ROBUST' Spirit Level Packs

cat.-no.	vials	length (cm)	cross section (mm)
698-040	3	40	60 x 26
698-060	3	60	60 x 26
698-080	3	80	60 x 26
698-090	3	90	60 x 26
698-120	3	120	60 x 26
698-180	3	180	60 x 26
698-200	3	200	60 x 26
698-240	3	240	60 x 26

## 698 ROBUST MAGNETIC

### 'ROBUST' SPIRIT LEVEL - MAGNETIC

- Magnetic body for ease of use
- Original BMI domed round vial with magnifying effect - unsurpassed readability
- Accurate to 0.5mm/m (including inverted measurements)
- 3x ultrasonic welded vials
- Torsion resistant 4-chamber profile
- 2mm thick aluminium construction
- 2 milled measuring surfaces
- Extra thick shock-absorbing rubber end caps
- Powder coated red



cat.-no.	vials	length (cm)	cross section (mm)
698-040-M	3	40	60 x 26
698-060-M	3	60	60 x 26
698-120-M	3	120	60 x 26

695 HIGHPRECISION

'HIGHPRECISION' SPIRIT LEVEL

- Original BMI domed round vial with magnifying effect - unsurpassed readability
- 5x more precise than ordinary levels
- Accurate to 0.3mm/m
- 2x ultrasonic welded vials
- Torsion resistant 4-chamber profile
- 2mm thick aluminium construction
- 2 milled measuring surfaces
- Extra thick shock-absorbing rubber end caps
- 60cm - 120cm; single handle
- 180cm & 200cm; dual handle

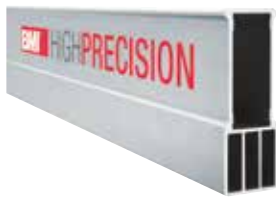

cat.-no.	vials	length (cm)	cross section (mm)
695-060-HP	2	60	76 x 26
695-100-HP	2	100	76 x 26
695-120-HP	2	120	76 x 26
695-200-HP	2	200	76 x 26

661 BAMBOO

WOODEN BAMBOO LEVEL

- Robust wooden level
- Original BMI domed round vial with magnifying effect - unsurpassed readability
- Accurate to 0.5mm/m (including inverted measurements)



cat.-no.	vials	length (cm)	cross section (mm)
661-060	2	60	60 x 26

## 715 ANGLESTAR

### FOLDING ANGLE LEVEL

- Robust foldable angle level
- Transfer or measure angles from 0° to 270°
- Smoothly locks in any angle from 0° to 270°
- Can be adjusted to fixed lockable positions (preset in 15° increments)
- Built-in spirit level
- Anodized aluminium body
- Range of sizes available
- Folds for easy transport

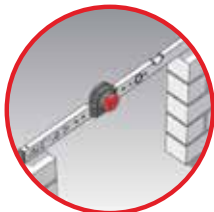

Works as a level



Works as a bevel



45° Angle

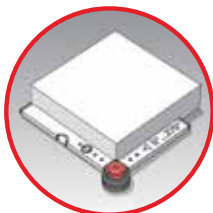

Outer 90° Angle

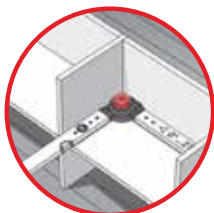

Inner 90° Angle



Gradient/Slope Measurement

cat.-no.	short leg (cm)	long leg (cm)
715-060-080	60	80
715-060-120	60	120

## 714 Folding Angle level

### FOLDING ANGLE LEVEL

- Easy to measure or transfer angles
- Vials to set the horizontal or vertical line.
- The device can also be used as a level or circle
- Built-in spirit level
- Robust light alloy profile, powder-coated



- 1 Two steel needle points, hardened, removable
- 2 Robust light alloy profile, powder-coated
- 3 Angle position can be fixed by a locking screw
- 4 The angle is directly read from the LCD display. Measuring range 355°. Indication in 0.1° increments

cat.-no.	length (cm)
714-600-D	60

**690 EUROSTAR PACK**

**'EUROSTAR' SPIRIT LEVEL PACK**

- 3 piece 'EUROSTAR' spirit level set
- Includes BMI carry bag



For more details about individual 'EUROSTAR' Spirit Levels, see page 8

cat.-no.	sizes (cm)
690-3PK-BAG	40cm + 80cm + 120cm (incl. BMI carry bag - cat.no. 710-130)

**699 SUPERSTAR PLUS PACK**

**'SUPERSTAR PLUS' SPIRIT LEVEL PACK**

- 4 different 'SUPERSTAR PLUS' packs available
  - 3 piece pack incl. BMI carry bag
  - 4 piece pack
  - 5 piece pack
  - 6 piece pack

cat.-no. 697-3PK-BAG (shown)



For more details about individual 'SUPERSTAR' Spirit Levels, see page 9

cat.-no.	sizes (cm)
697-3PK-BAG	40cm + 80cm + 120cm (incl. BMI carry bag - cat.no. 710-130)
697-4PK	40cm + 80cm + 120cm + 200cm
697-5PK	40cm + 60cm + 80cm + 120cm + 200cm
697-6PK	40cm + 60cm + 80cm + 100cm + 120cm + 200cm

**698 ROBUST PACK**

**'ROBUST' SPIRIT LEVEL PACK**

- 2 different 'ROBUST' packs available
  - 3 piece pack incl. BMI carry bag
  - 4 piece pack

For more details about individual 'ROBUST' Spirit Levels, see page 10

cat.-no. 698-3PK-BAG (shown)



cat.-no.	sizes (cm)
698-3PK-BAG	60cm + 120cm + 200cm (incl. BMI carry bag - cat.no. 710-205)
698-4PK	40cm + 60cm + 120cm + 200cm



## 710 BELT POUCH/CARRY BAG

### SPIRIT LEVEL BELT POUCH

- Belt pouch to suit BMI Ultrasonic, Torpedo, Magnetic Torpedo & Line level.



### SPIRIT LEVEL CARRY BAGS

- Soft padded bag to suit all BMI spirit levels.
- Strap to carry easily with zipper at one end for safety.
- Available in three sizes: 70, 130, 205cm.



cat.-no.	Description	sizes (cm)
710-0025	Suits Ultrasonic, Torpedo, Magnetic Torpedo & Line level	25cm
710-070	Suits spirit levels up to 60cm in size	70cm
710-130	Suits spirit levels up to 120cm in size	130cm
710-205	Suits spirit levels up to 200cm in size	205cm

## LEVEL DISPLAY STAND

### LEVEL DISPLAY STAND

- Display your BMI level range to customers
- Designed to display up to 24 levels in a range of sizes
- High quality display stand
- Robust steel construction
- Stock packages available



\*Levels not included

cat.-no.	capacity	Suits
DISP-698/695	24	High Precision & Robust
DISP-690/697/695	15	Eurostar, SuperStar & Robust

## 604 LEVELBOY - ELECTRONIC LEVEL

### 604 LEVELBOY - ELECTRONIC LEVEL

- Electronic module identical to Leveltronic
- spring clip (e.g. for the terminals on plastic pipes)
- Prismatic contact surfaces with strong magnetic clamps
- brass knurled screws used for fastening to spirit levels, levelling boards,
- Vials: Normal position 0.50 mm / m
- Electronic inclinometer: 0° and 90°: 0.05°, 1° - 89°: 0.2°;
- Display in %, mm / m, and inch / ft.

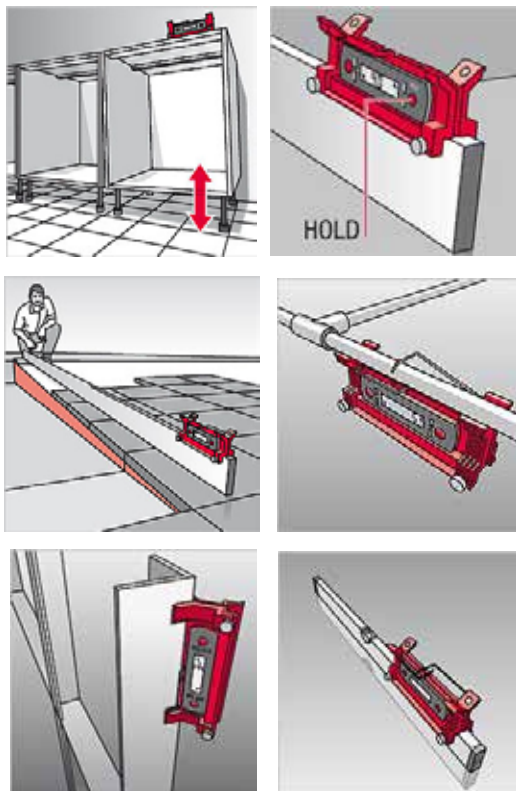

cat.-no.	vials	length (cm)	cross section (mm)
604-020	1	20	60 x 26

## 601 INCLI TRONIC PLUS

### 'INCLI TRONIC PLUS' SPIRIT LEVEL

- Original BMI domed round vial with magnifying effect - unsurpassed readability
- Electronic inclinometer:
  - Accuracy at 0° and 90° ± 0.1°;
  - Accuracy at 1° to 89° ± 0.3° B
- Battery: E-block 9 Volt 6LR61
- Different angles can be set as a reference/origin angle
- Automatic shut off after 7 minutes
- Accurate to 0.5mm/m (including inverted measurements)
- 3x ultrasonic welded vials
- Torsion resistant 4-chamber profile
- 2mm thick aluminium construction
- 2 milled measuring surfaces
- Extra thick shock-absorbing rubber end caps



cat.-no.	vials	length (cm)	cross section (mm)
601-120	2	120	60 x 26

## 601 INCLI TRONIC PLUS

### 'INCLI TRONIC PLUS' SPIRIT LEVEL

- Original BMI domed round vial with magnifying effect - unsurpassed readability
- Electronic inclinometer:
  - Accuracy at 0° and 90° ± 0.05°;
  - Accuracy at 1° to 89° ± 0.2° B
- Battery: 2x AAA 1,5 V
- Digital display, with automatic rotation of the display when working overhead
- intermediate angles can be set as reference angles
- 30 operating hours,
- automatic switch off in 7 minutes.
- two different beep tones for left and right approach to the Horizontal or Vertical

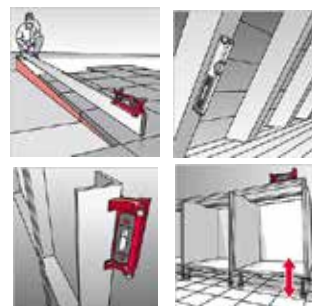

cat.-no.	vials	length (cm)
604-030-M	2	30

## 692-M ULTRASONIC

### 'ULTRASONIC' SPIRIT LEVEL

- Magnetic
- Original BMI domed round vial with magnifying effect - unsurpassed readability
- Accurate to 0.5mm/m
- Optimal reading by vertical head vial
- 2x ultrasonic welded vials
- 1.8mm thick aluminium construction
- Extra thick shock-absorbing rubber end cap



cat.-no.	length (cm)	cross section (mm)
692-020-M	20	50 x 22
692-025-M	25	50 x 22

## 689-M TORPEDO

### 'TORPEDO' SPIRIT LEVEL

- 2 x Strong Magnets
- Aluminium die-cast level
- Milled measuring surface
- Horizontal block vial
- Accurate to 0.5mm/m
- Comes with BMI belt pouch



cat.-no.	length (cm)
689-025-M	25

## 674-M TRIVELLE

### MAGNETIC TORPEDO LEVEL

- 3 vials for horizontal, vertical and 45° measurements

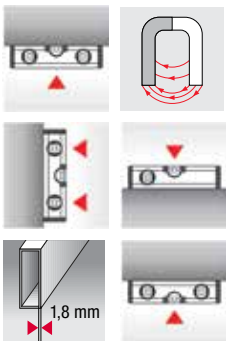

cat.-no.	length (cm)	cross section (mm)
674-020-M	20	42 x 17

## 675 LINE-LEVEL

### LINE LEVEL

- Tough plexiglass vials
- Bullseye level in end
- Eyelets for use with levelling lines
- ABS plastic construction

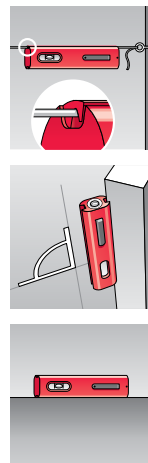

cat.-no.	length (cm)	cross section (mm)
675-012	12	29 x 17

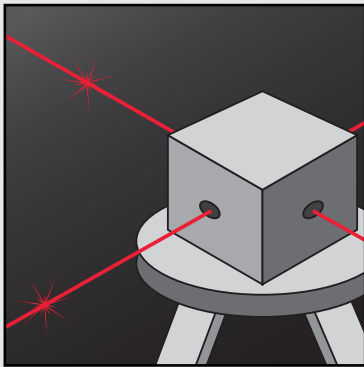

## Construction Lasers

### Ingenious, practical devices

- Waterproof to IP67 - use it even in the worst conditions on site
- Set it up, switch it on, and get to work with the press of just one button!
- Robust, accurate and safe with ESP (Electronic Safety Program)
- Can be run on 240V, or by battery
- Complies with laser Class 2 international safety standards



### NAUTILUS IPX7

#### CONSTRUCTION LASER

- Range of up to 250m
- Accurate to within  $\pm 2.6$  mm/30m
- Self-Levelling
- Robust aluminium casing
- Laser unit encompassed by shock absorber to protect from bumps, scrapes and knocks
- Waterproof IP67 compliant
- Rechargeable Battery (Ni-MH)
- Electronic Safety Program - Automatic laser stop in case of shocks or changes of position
- Folds for easy transport
- Supplied in convenient carry case



**Electronic Safety Program:**  
Automatic laser stop in case of shocks or changes of position



**Waterproof**  
**IP67 compliant**



**Rechargeable Battery**  
(Ni-MH; without memory effect)

Robust aluminium casing

Laser unit encompassed by shock absorber for safety

Tripod included

**Photodiode handheld receiver allows you to make full use of the laser within the working distance of up to 250m**

- Acoustic and optical receiving signal
- LCD display on front of unit for easy and practical use

**COMPLETE SET WITH PRACTICAL CARRY BAG**



#### Technical Data - Rotating Laser

<b>Laser type</b>	Red diode laser, wavelength 635nm
<b>Output</b>	< 1 mw, Laser Class 2
<b>Self-levelling range</b>	approx. $\pm 4^\circ$ , corresponds to $\pm 6\%$
<b>Levelling accuracy</b>	$\pm 2.6$ mm/30m
<b>Levelling time</b>	< 30 seconds
<b>Operating temp.</b>	-10° C to 50° C
<b>Range</b>	250m $\emptyset$ with handheld receiver
<b>Speed</b>	600 rotations/minute
<b>Power supply</b>	Mains power, or battery pack (Ni-MH) 4x 1.2V batteries, size A LR14
<b>Service life</b>	50 Hours
<b>Protective system</b>	IP67 waterproof
<b>Tripod connection size</b>	5/8" (tripod)
<b>Dimensions</b>	approx. 170 x 170 x 220mm
<b>Weight</b>	2.5kg

#### Technical Data - Handheld Receiver

<b>Range</b>	200 m
<b>Protective system</b>	IP67 waterproof
<b>Power supply</b>	2x 1.5V batteries, size AA LR6
<b>Service Life</b>	According to usage

cat.-no.

dimensions - Laser Unit Only (mm)

Range

648-03-AH-SET

170 x 170 x 220

up to 250m



## multiLASER 3D - RED

### SELF LEVELING 360° LINE LASER

- multiLASER 3D RED is a professional multi-plane laser, fully self-leveling, which ensures perfect visibility of laser lines indoors and a large range in the field with an optional detector
- Power: 1 mW each beam, class II
- Accuracy: +/- 2mm / 10m (+/- 0.2mm / 1m)
- Self-leveling system: magnetic pendulum
- Type of laser beam: fixed / keyed
- Working range:
- Power supply: Li-ion battery
- Battery voltage: 4.2V
- Battery capacity: 5200mAh
- Instrument weight: 0.8 kg
- **No optional accessories included**



cat.-no.	dimensions - Laser Unit Only (mm)	Range
654-3DG	130 x 90 x 120	up to 100m

## multiLASER 3D - GREEN

### SELF LEVELING 360° LINE LASER

- multiLASER 3D GREEN is a professional multi-plane laser, fully self-leveling, which ensures perfect visibility of laser lines indoors and a large range in the field with an optional detector
- Power: 1 mW each beam, class II
- Accuracy: +/- 2mm / 10m (+/- 0.2mm / 1m)
- Self-leveling system: magnetic pendulum
- Type of laser beam: fixed / keyed
- Working range:
- Power supply: Li-ion battery
- Battery voltage: 4.2V
- Battery capacity: 5200mAh
- Instrument weight: 0.8 kg



### Included Accessories:



Wall Clamp



Multifunction Adaptor  
(Magnetic)



Leveling plate with fine  
adjustments

cat.-no.	dimensions - Laser Unit Only (mm)	Range
654-3DR	130 x 90 x 120	up to 100m

autoCROSS 4 - RED

**SELF-LEVELLING CROSSLINE LASER**

- Horizontal and vertical lines can be switched on separately. Can be used as optical chalk line. Complete in a bag. Batteries included.
- Super High Visibility Beams
- An aperture angle of 140° vertical and 120° horizontal gives you extraordinary line lengths.
- Multipurpose attachment accessory (45° angle)
- Laser type: Cross line, Horizontal line, Vertical line
- The laser wavelength: 635 nm
- Levelling accuracy:  $\pm 3$  mm/10 m



**Included Accessories:**



Multifunction Adaptor  
(Magnetic)

cat.-no.	dimensions - Laser Unit Only (mm)	Range
654-3DG	130 x 90 x 120	up to 100m

autoCROSS 4 - GREEN

**SELF-LEVELLING CROSSLINE LASER**

- Horizontal and vertical lines can be switched on separately. Can be used as optical chalk line. Complete in a bag. Batteries included.
- Super High Visibility Beams
- An aperture angle of 140° vertical and 120° horizontal gives you extraordinary line lengths.
- Multipurpose attachment accessory (45° angle)
- Laser type: Cross line, Horizontal line, Vertical line
- The laser wavelength: 635 nm
- Levelling accuracy:  $\pm 3$  mm/10 m



**Included Accessories:**



Multifunction Adaptor  
(Magnetic)



Holding clamp  
for Receiver



Receiver

cat.-no.	dimensions - Laser Unit Only (mm)	Range
649-015	130 x 90 x 120	up to 100m

**LASERBOY II**

**CONSTRUCTION LASER**

- Class 2, power output <1 mW
- Wavelength 670 nm
- Range up to approx. 30 m
- 2 x 1.5V batteries (LR03 Micro)
- reverse battery protected
- 8 hours of continuous light
- dust- and splash-water protected
- Dimensions L/W/H approx.: 165 x 55 x 45 mm
- Vial for precise alignment in stand-alone operation
- Two brass knurled screws ensure tight connection

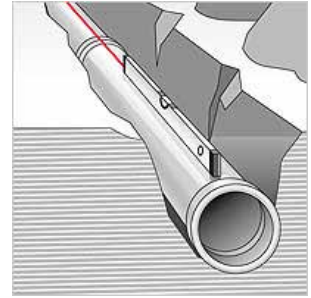
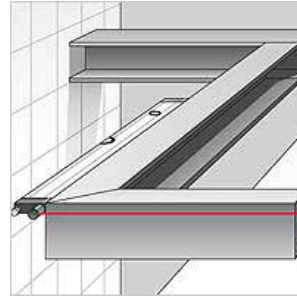

**Accessories:**

**Beam deflecting with adapter**



Beam deflecting prism and adapter; becomes basic application "Right Angle" possible

**90° beam deflecting prism**



90% of the light is deflected by 90 ° beam splitter prism for LASERBOY, LASERKING and LASER PRO 635 incliTronic plus, 10% are emitted in the laser axis. Accuracy 0.15 mm/m.



**SIEPER Group**  
**Hardware**

101-109 Deakin St,  
Silverwater NSW 2128  
AUSTRALIA

PH: 02 9352 0600  
FAX: 02 9748 0566  
EMAIL: [sales@sieper.com.au](mailto:sales@sieper.com.au)

[www.sghardware.com.au](http://www.sghardware.com.au)